

Part Specs

Pin Out & Specs

- Voltage: 14-84V (safe for 3-20S)
- Continuous Current: 50V/350A,75V/250A
- Max Current: 800A
- Supported sensors: ABI, HALL, AS5047, AS5048A
- ERPM: 150000
- Phase filter: Yes
- Motor wire: 8AWG
- Power cable: 8AWG
- Input source: PPM, ADC, NRF, UART, PAS
- Communication ports: USB, CAN, UART, SPI, IIC
- CPU adaptation frequency: 168MHz (with 32F405)
- Configurable RPM, current, voltage and power limits
- Waterproof level (with water cooling enclosure): IP67
- Size: 200*94.6*50mm (Including the height of water pipes and electrolytic capacitors)
- Weight: 1.74 kg

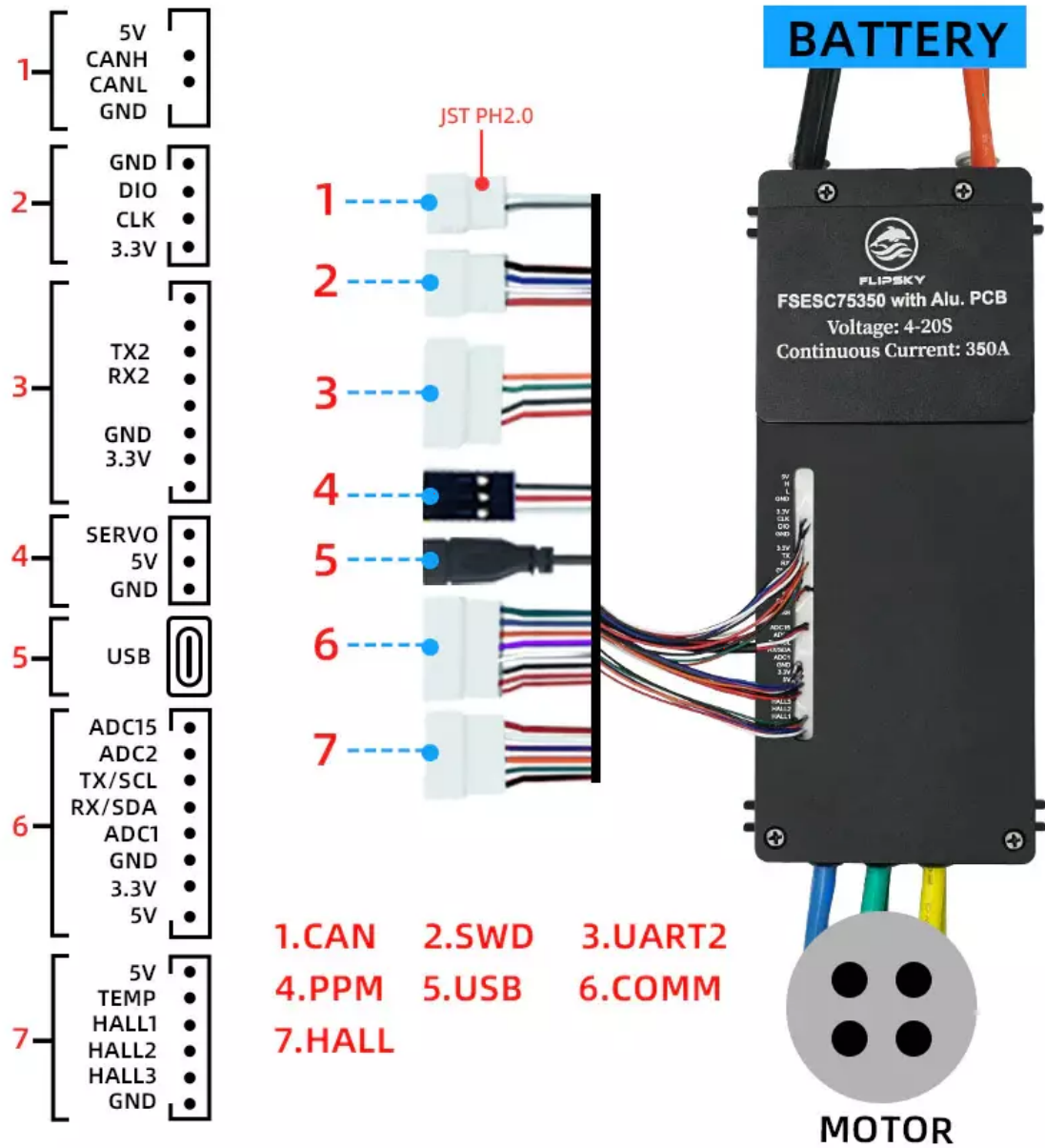

Revision #2

Created 17 May 2026 20:40:05 by Caicheng Li

Updated 17 May 2026 20:40:24 by Caicheng Li